

ARCHITECT DESIGN SPECIFICATION GUIDE

With more than a century of experience, Organized Living's unwavering commitment to meeting residents' needs has inspired the strongest, most trusted storage solutions on the market. We understand the intricacies of Multifamily projects and are here to support Architects and Owner/Developers throughout the specification process. Our experience makes it easy for you to get closet specification right.

Use this guide to confidently specify Organized Living products in your next project.





TABLE OF CONTENTS

About Organized Living	3
Product Categories	4
Product Lines	6
Bid360 Snapshot	7
Steps to Specify	8
Specification Codes	9
Fixed Wire	16
• Lifetime™	
Fixed Wood	19
• VUE®	
Adjustable	22
• freedomRail®	
Built-In	25
• Select®	
ADA Storage	28
Green Products	29

ABOUT ORGANIZED LIVING

Organized Living has helped shape the building products industry for more than 100 years. As the industry leader of high-quality home storage and organization products, Organized Living offers a full breadth of organization solutions for every project, home, budget, and need.

Superior products combined with the advanced technology of Bid360™ is sure to simplify closets once and for all, by working smarter, collaborating better, and installing faster than any other closet system. Closets are no longer complicated when you partner with Organized Living.

We make it easy...

- Working with **Owner/Developers** to establish Design Specification Levels for their entire portfolio
- Providing **Architects** a way to confidently specify closets without being a closet designer
- Advancing technology for **General Contractors** to get bids quickly and accurately
- Providing tools and resources for **sub-contractors** and our **Installing Dealers** to install accurately, on-time, and on budget

We've thought of everything so you don't have to!



Learn more about
Organized Living.
OrganizedLiving.com/Company



"The installation process is so much easier! It helps us speed up the construction timeframes."

Kyle Salay, *General Manager of Operations*
Brookstone Realty Management



Scan to hear more
from **Kyle Salay.**
OrganizedLiving.com/multifamily

PRODUCT CATEGORIES

PRODUCTS TO SATISFY RESIDENTS' NEEDS

Organized Living storage solutions are engineered for **strength** and **versatility**. When you choose Organized Living products you are confidently choosing quality products that go up and stay up!

Storage shelving is grouped into three categories - fixed, adjustable, and built-in. Only Organized Living offers products in each category so you can specify closet shelving for an entire project using one brand and one specification.



3 CATEGORIES OF CLOSET SHELVING

Organized Living's sole focus is storage and organization, and we concentrate on providing Multifamily professionals with storage products that excite residents and meet their needs.

From fixed shelving for projects on a budget, adjustable for evolving needs and abilities, to built-in for a custom feel, our three categories of closet shelving meet the need every time.



Fixed: Fixed shelving offers an economical solution for price-conscious projects while still providing residents with the durability and strength they expect.

- Fixed mounted shelving, no adjustability
- Used in applications that require strength and durability

Product Lines:
Lifetime™ Ventilated
Shelftech™ Ventilated
VUE®



Adjustable: Adjustable shelving is used to maximize space and differentiate projects while staying on budget. Residents can customize their closet at move-in.

- Fully adjustable, move components anytime without tools
- Eliminate wasted space
- Hang clothes within reach or shift shelving to make room to store items

Product Lines:
freedomRail®



Built-In: Built-in closet shelving gives residents the high-end feel of custom storage while aligning to other amenities within the property.

- Limited adjustability, often referred to as moveable
- Shelves can move up and down to accommodate variations of stacked clothing or hanging rod height

Product Lines:
Select®

PRODUCT LINES AT A GLANCE

FIXED

Ventilated Wire



Lifetime is the standard fixed ventilated wire shelving that is the strongest in the industry. It installs with the strongest hardware to offer the weight load capacity required by architects and quality builders. It is used in applications that require strength and durability. Ideal for multifamily projects when long-term durability is needed.

ADJUSTABILITY None. Can be installed to be ADA compliant.

COLORS White and Nickel

WEIGHTLOAD CAPACITY 75 lbs per foot of shelving.

ANCHOR SYSTEM Mounts to drywall with patented Tri-Loc® anchor system.

WARRANTY Lifetime Limited

LEED POINTS Yes

Shelftech is economical fixed ventilated shelving with steel gauges similar to competitive products developed to be sold in big box stores. Generally used where low cost is the driving factor.

ADJUSTABILITY None. Can be installed to be ADA compliant.

COLORS White

WEIGHTLOAD CAPACITY 45 lbs per foot of shelving

ANCHOR SYSTEM Mounts to drywall with pin driven system.

WARRANTY 10 Year Limited

LEED POINTS Yes

VUE®



VUE is a refined fixed wood storage system with no exposed hardware and a patent-pending design for gap-free installation. Easy installation, high quality materials, and superior strength meet the needs of building professionals. Ideal as an economical shelf and rod solution for home builders or a fixed value-add option for multifamily projects. VUE appeals to homebuyers and residents who prefer a solid shelf solution over fixed wire shelving and do not require adjustability.

ADJUSTABILITY None. Can be installed to be ADA compliant.

COLORS *Hardware:* White and Nickel;
Smooth Finishes: White, Century Gray, Chocolate Pear

WEIGHTLOAD CAPACITY 85 lbs per foot of shelving

ANCHOR SYSTEM Sidewall Brackets install into drywall with proprietary hardware. Shelf Brackets install directly in wood or metal studs. Shelves secure to brackets with proprietary high strength adhesive film.

WARRANTY 10 Year Limited

LEED POINTS Yes

ACCESSORY OPTIONS Corner Clothes Rod, Shelf Towers with or without accessory add-ons (Drawers, Shoe Shelves, Chrome Baskets).

ADJUSTABLE

freedomRail®



freedomRail is a truly adjustable storage system that can be easily adjusted by the homeowner or resident. Shelves and accessories can be moved up, down, left, or right at any time without tools. Users can add shelves or accessories to their system or completely change their closet layout without drilling new holes. freedomRail's thicker steel and superior hardware give it its strength and ability to be completely adjustable, appealing to the homeowner or resident who wants control of their closets to meet their changing needs. freedomRail also offers a full line of garage storage and accessories.

ADJUSTABILITY Full, ADA compliant

COLORS *Hardware:* White and Nickel;
Smooth Finishes: White, Century Gray, Modern Cherry, Chocolate Pear
Live Finishes: Midnight, Driftwood, Cypress, Snowdrift

WEIGHTLOAD CAPACITY 170 lbs per linear foot.

ANCHOR SYSTEM Heavy-gauge Rail secures into steal or wood studs and drywall with proprietary anchor and screw system.

WARRANTY 10 Year Limited

LEED POINTS Yes

ACCESSORY OPTIONS Acrylic Shelf Divider, Book Ends, Cubbies, Desk Top, Filing Drawers, Jewelry Inserts, OBoxes, Sliding Tie and Belt Rack, Shoe Fence, Shoe Shelves, Valet Rod, Ventilated Shelf Divider and Reveal Wire Baskets, Canvas Baskets, Hampers, Pant Rack, Shoe Racks, Shoe Shelves

BUILT-IN

Select®



Select is a traditional, built-in storage solution. The heavy-gauge Rail, furniture-grade wood, and proprietary hardware combine to create the strongest rail-based wood closet system available. Select offers homebuyers and residents the built-in look of a custom closet.

ADJUSTABILITY Limited. Can be installed to be ADA compliant.

COLORS: *Smooth Finishes:* White, Century Gray, Chocolate Pear
Live Finishes: Snowdrift

WEIGHTLOAD CAPACITY 170 lbs per linear foot.

ANCHOR SYSTEM Heavy-gauge Rail secures into steal or wood studs and drywall with proprietary anchor and screw system.

WARRANTY 10 Year Limited

LEED POINTS Yes

ACCESSORY OPTIONS Chrome Baskets, Drawers with Soft-Close Full-Extension Glides, Doors with Soft-Close Hinges, Shoe Shelves, Tie and Belt Rack and Valet Rod.



BID360 SNAPSHOT

TECHNOLOGY TO SIMPLIFY SPECIFYING

Work smarter, collaborate better, and specify faster with the only complete construction project workflow software for closet shelving.

Organized Living has partnered with **Bid360™** to launch the first-ever bid and project management tool for closets in the Single Family and Multifamily industries. **Bid360** can generate specification codes, create designs, complete bids, order product, and facilitate installation.

Specifying closets has never been easier! You do not have to be a closet designer or a closet expert, let Bid360 do the work for you.

- Configure custom Design Spec Levels to use on all projects.
- Use specification codes that are tied to an actual closet design.
- Confidently spec products that are high quality, ADA compliant, and sustainable.



Request a Bid360 Demo Today.

OrganizedLiving.com/Multifamily/Bid360/Contact



STEPS TO SPECIFY CLOSETS

- 1. Create custom Design Spec Levels for Owner Developer's brands and brand levels.**
 - Design Spec Levels can be a combination of products based on the needs of the project. Design Spec Levels provides average feet of storage, and the Organized Living specification code.
- 2. Architect adds specification code to blueprint.**
 - The code can be added directly on the closets within the floor plan or added as part of the Part 3 Schedule in the 3 Part Specification, in the Legend or Elevation Notes.
- 3. General Contractor contacts nearest Organized Living Installing Dealer for quote.**
- 4. Organized Living Dealer provides quote and completed take-off designs via a Bid360 link or pdf attachment.**
- 5. General Contractor accepts quote and designs via Bid360.**
- 6. Organized Living Dealer uses Bid360 as a project management tool to field measure, order, and install to keep project on time and on budget.**

This 6 step process is the **ONLY** way to ensure the closets you specify are installed accurately, timely and on budget.

WHAT MAKES THIS EASY?

- You do not have to design closets.
- No details required in elevation notes.
- Spec codes enhance communication downstream and through every project phase.
- Specification codes are universal – they work for all closet areas and across every closet dealer.
- Your spec will hold throughout the entire construction process.
- You're ensuring Organized Living quality every time.



DESIGN SPEC LEVELS AND SPECIFICATION CLOSET CODES

Use Organized Living Design Spec Levels to specify every closet in every project – regardless of the size or shape of the closet. A Design Spec Level is a matrix for each Organized Living product line that is organized by area (i.e. entry, pantry, walk-in bedroom, etc.) and by closet design level.

Organized Living team of professional closet designers have developed five levels of closet designs. As closet experts we know what products are most used, what satisfies residents, what is cost effective and what is the best use of space. You can choose the closet level based on budget, amount of storage, or quality of storage.

Design Spec Levels can be custom made for each Owner Developer and their build type (student housing, high-rise, etc.). The Design Spec Level serves as a cheat sheet for you to quickly and easily specify closets by using specification codes. These codes are the key to ensuring closets are specified and installed accurately every time!

Add the **Organized Living specification codes** to any project drawing and the General Contractor will work with an Organized Living Installing Dealer to complete the design and installation. Shelving designs, shelving legends, and closet elevations are no longer needed. You save time and guarantee specifications are met.

Add the **Industry specification code** to any project drawing to specify generic/non-Organized Living shelving product. The Industry Specification Code is based on standard shelving notations when historically, architects had to specify the shelving product and create the closet design.



WE MAKE SPECIFYING ORGANIZED LIVING PRODUCTS EASY!

Before getting started, read the descriptions below to understand how specification codes are created and used.





The specification codes work regardless of the size or shape of the closet. The Organized Living team of designers and the software team of Bid360 have developed design and project management software utilizing AI technology to design each closet in a unit and in a project.

Product Line: Organized Living product line designation. Full breadth of product lines shown below:



FR3 Adj 2S/1R 14"

Design Level: Describes the amount of storage and upgraded components within the design. The five design levels are Economy, Basic, Essential, Deluxe and Premium. These design levels were developed by closet designers based on years of experience designing for Multifamily projects.

	BASIC • DESIGN LEVEL 2	ESSENTIALS • DESIGN LEVEL 3	DELUXE • DESIGN LEVEL 4	PREMIUM • DESIGN LEVEL 5	
3' ENTRY					
	Total Wall Length	3'	Total Wall Length	3'	
	Total Feet of Storage	6'	Total Feet of Storage	8'	
	Specification Code:	FR2 Adj 2S/1R 14"	Specification Code:	FR3 Adj 2S/1R 14"	
			Total Feet of Storage	12'	
			Specification Code:	FR4 Adj 2S/1R/Canvas Basket 14"	
				Specification Code:	FR5 Adj 2S/1R/Shoe 14" Canvas

FR3 Adj 2S/1R 14"

Feature: For fixed shelving, there are no features called out. For product lines that are differentiated by features such as Adjustable or Moveable, this is noted to ensure the product installed meets specifications.



Fixed shelving is securely mounted to the wall and cannot be moved or adjusted. A resident would have no ability to customize their storage at move-in. Fixed shelving is often used in price-conscious projects while still providing residents durability and strength.

LT3 2S/2R, 1S/1R 12"



Adjustable shelving can be adjusted left, right, up or down to meet the needs of the resident. This is ideal for allowing residents to unpack with ease and customize their closet. A resident could easily adjust their closet to give themselves more long-hang storage if someone has a lot of dresses or a shoe-lover resident could add shelves to increase their shoe storage.

fR3 Adj 2S/1R 14"



Moveable shelving offers limited adjustability and usually just allows a resident to move their shelves up or down to provide more space for a stack of folded sweaters.

SE4 Mov 2S/1R 14"



Design Configuration: Describes the design configuration with standard closet design designation. The design configuration is spelled out left to right as if someone was inside the closet explaining what would go on each wall.

SE4 Mov 2S/2R, SS/Baskets, 2S/1R 14"

- SS – Shelf Stack
- #S – Shelf Stack with specified shelf number
- 1S/1R – 1 Shelf/1 Rod (*Long Hang*) (68" AFF)
- 2S/1R – 2 Shelf/1 Rod (*Long Hang with shelf above*) (shelf 84" AFF/ shelf and rod 68" AFF)
- 2S/2R – 2 Shelf/2 Rod (*Double Hang*) (shelf and rod 84" and 42" AFF)
- Shoe – Shoe storage
- Accs – Accessories

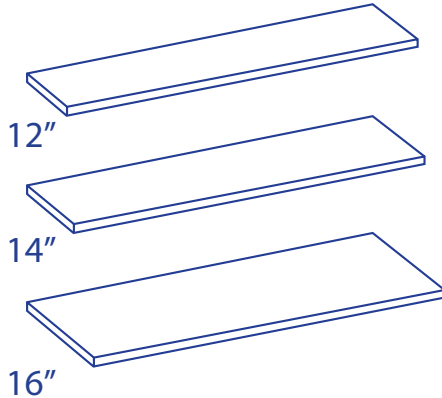

Shelf Depth: Describes the dimension of the shelf depth.

fR3 Adj 2S/1R 14"



ADA: To ensure a closet design is ADA compliant, simply add ADA to the beginning of each specification code.

See page 30 for more information on ADA.

ADA SE3 Mov 2S/2R, SS, 2S/1R 14"

Organized Living Specification

Industry Specifications

Product Line

Fixed

ST - Shelftech

LT - Lifetime

VU - VUE

Adjustable

fR - freedomRail

Built-in

SE - Select

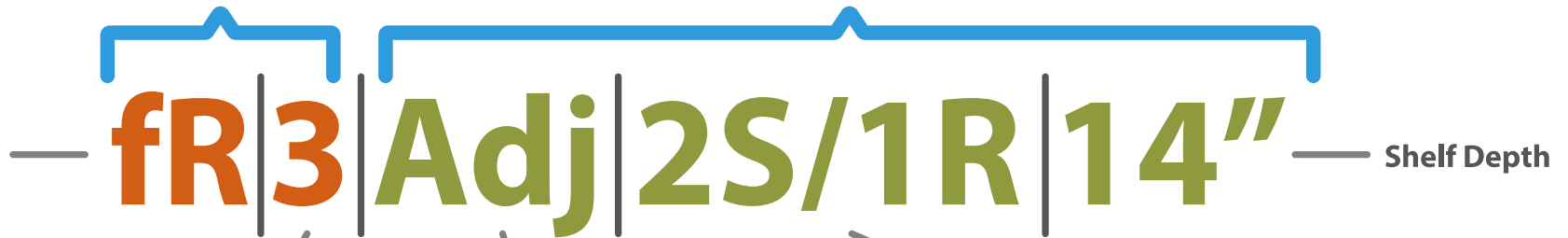

Design Level

2 - Basic

3 - Essential

4 - Deluxe

5 - Premium

Feature

___ - Fixed Shelving

Mov - Moveable Shelving
(limited adjustability)

ADJ - Adjustable Shelving

Design Configuration (left to right)

SS - Shelf Stack

#S - Shelf Stack with specified number of shelves

1S/1R - 1 Shelf/1Rod (*Long Hang*) (68" AFF)

2S/1R - 2 Shelf/1 Rod (*Long Hang with shelf above*)
(shelf 84" AFF/shelf and rod 68" AFF)

2S/2R - 2 Shelf/2 Rod (*Double Hang*) (shelf and rod
84" AFF/shelf and rod 42" AFF)

Shoe - Shoe Storage

Accs - Accessories

SPEC CODES IN ACTION

The Design Spec Level for each product line serves as your guide for finding and using the specification code. Use the specification code from the Design Spec Level to specify the product line, area, and design level. **Specification codes, from a Design Spec Level, can be applied directly to the floor plans on the drawing or listed in a legend.**

This guide includes universal Design Spec Level matrix for each product line and can be found on pages 15-28.

Organized Living Specification

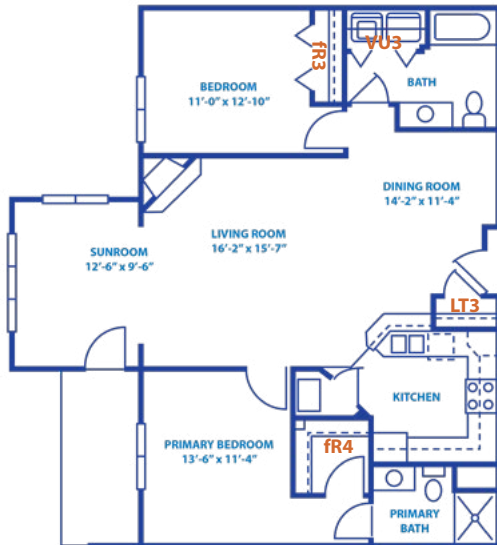

Industry Specification + Organized Living

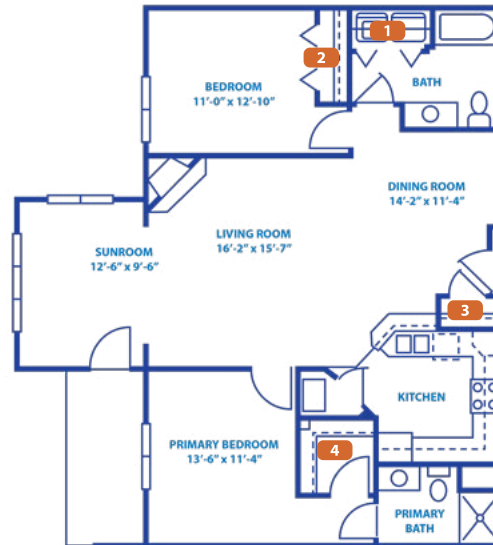

UNIT LEGEND	
1	VU3 1S/1R 12"
2	fr3 Adj 2S/2R, SS, 2S/1R 14"
3	LT3 2S/1R 12"
4	fr4 ADJ 2S, SS/accs, 2S/1R 14"

For a closed specification, simply use the **Organized Living Specification**. This is sufficient to get a quote and ensure your specs are met.

For an **Industry Specification + Organized Living** specification, copy the specification code from the Design Spec Levels directly to the floor plan **or** add to the unit legend.



START SPECIFYING

Organized Living is focused on providing Architects with products that will increase retention and rental income. We offer a full breadth of high-quality products for every project type, from affordable housing to luxury apartments.

In the following pages, you will learn about each product line and access the specification codes you need.

Each product line has its own Design Specification Level matrix. Simply choose the storage area and design level and add the specification code from the matrix to your blueprint.

The size and shape of the closet does not matter. *It's that easy!*



FIXED WIRE

ADVANTAGES OF FIXED WIRE

Our economical fixed Ventilated Wire system can meet the budget and needs of any project. **Lifetime™** is the strongest fixed wire solution available on the market, holding 75 lbs per linear foot of shelving, providing the strength and durability residents expect.

Why Specify Lifetime?

Lifetime™ Ventilated holds 75 pounds per linear foot, making it the strongest fixed wire shelving option available on the market. It's the perfect choice when long-term **strength and durability matter!**

- 30% more steel than competitive ventilated wire systems.
- Installed with proprietary, Tri-Loc hardware offering a weight load capacity of 75 lbs per linear foot.
- No blocking is required! Installed 100% after paint and does not interfere with other trades.
- Can be installed to be ADA compliant.
- Manufactured with epoxy powder coating to resist cracking, chipping, peeling, and discoloration while releasing no harmful VOCs.

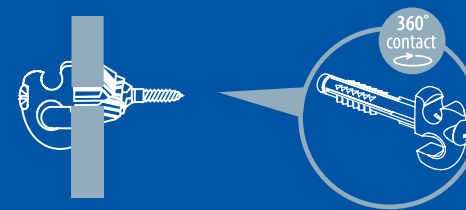

Design Spec Level Examples

BASIC • DESIGN LEVEL 2

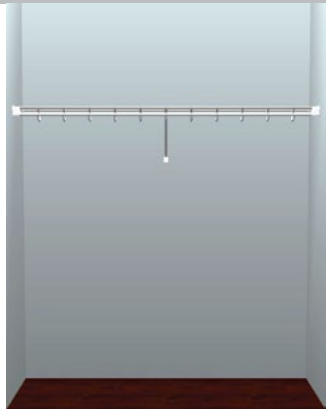

Single Hang

LT2 1S/1R 12"

Avg Price per Foot of Wall Length \$15

ESSENTIALS • DESIGN LEVEL 3

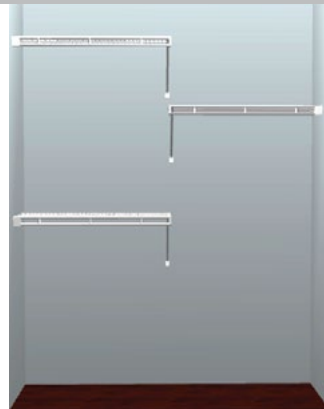

Double and Single Hang

LT3 2S/2R, 1S/1R 12"

Avg Price per Foot of Wall Length \$18

DELUXE • DESIGN LEVEL 4

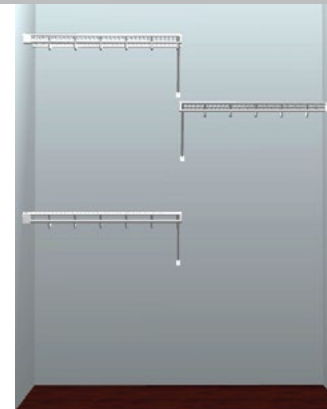

**Double and Single Hang
Open Slide**

LT4 2S/2R, 1S/1R 12"

Avg Price per Foot of Wall Length \$22

PREMIUM • DESIGN LEVEL 5

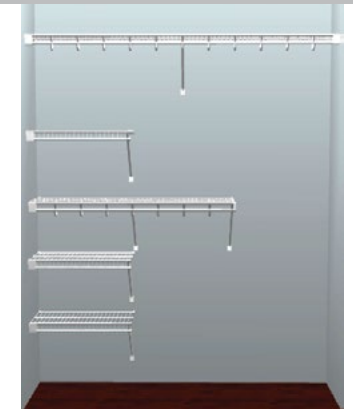

**Double and Single Hang
Open Slide, Shelf Stack**

LT5 5S, 2R, 1R 12"

Avg Price per Foot of Wall Length \$27

	BASIC • DESIGN LEVEL 2	ESSENTIALS • DESIGN LEVEL 3	DELUXE • DESIGN LEVEL 4	PREMIUM • DESIGN LEVEL 5
3' ENTRY	 <p>Total Wall Length 3' Total Feet of Storage 3' Specification Code: LT2 1S/1R 12"</p>	 <p>Total Wall Length 3' Total Feet of Storage 6' Specification Code: LT3 2S/1R 12"</p>	 <p>Total Wall Length 3' Total Feet of Storage 6' Specification Code: LT4 2S/1R 12"</p>	 <p>Total Wall Length 3' Total Feet of Storage 9' Specification Code: LT5 2S/1R/Shoe 12"</p>
5' PANTRY	 <p>Total Wall Length 5' Total Feet of Storage 20' Specification Code: LT2 4S 12"</p>	 <p>Total Wall Length 5' Total Feet of Storage 25' Specification Code: LT3 5S 12"</p>	 <p>Total Wall Length 5' Total Feet of Storage 25' Specification Code: LT4 5S 12"</p>	 <p>Total Wall Length 5' Total Feet of Storage 25' Specification Code: LT5 5S 16"</p>
3' LINEN	 <p>Total Wall Length 3' Total Feet of Storage 12' Specification Code: LT2 4S 16"</p>	 <p>Total Wall Length 3' Total Feet of Storage 15' Specification Code: LT3 5S 12"</p>	 <p>Total Wall Length 3' Total Feet of Storage 15' Specification Code: LT4 1S 12"/4S 16"</p>	 <p>Total Wall Length 3' Total Feet of Storage 15' Specification Code: LT5 5S 16"</p>
6' LAUNDRY	 <p>Total Wall Length 6' Total Feet of Storage 6' Specification Code: LT2 1S/1R 12"</p>	 <p>Total Wall Length 6' Total Feet of Storage 6' Specification Code: LT3 1S 16"</p>	 <p>Total Wall Length 6' Total Feet of Storage 12' Specification Code: LT4 2S/1R 12"</p>	 <p>Total Wall Length 6' Total Feet of Storage 12' Specification Code: LT5 1S 16"/1S/1R 12"</p>
6' REACH-IN BEDROOM	 <p>Total Wall Length 6' Total Feet of Storage 6' Specification Code: LT2 1S/1R 12"</p>	 <p>Total Wall Length 6' Total Feet of Storage 9' Specification Code: LT3 2S/2R, 1S/1R 12"</p>	 <p>Total Wall Length 6' Total Feet of Storage 9' Specification Code: LT4 2S/2R, 1S/1R 12"</p>	 <p>Total Wall Length 6' Total Feet of Storage 16' Specification Code: LT5 5S/2R/1R 12"</p>
6'x6' WALK-IN BEDROOM	 <p>Total Wall Length 12' Total Feet of Storage 10' Specification Code: LT2 1S/1R 12"</p>	 <p>Total Wall Length 12' Total Feet of Storage 16' Specification Code: LT3 2S/2R, 1S/1R 12"</p>	 <p>Total Wall Length 12' Total Feet of Storage 16' Specification Code: LT4 2S/2R, 1S/1R 12"</p>	 <p>Total Wall Length 12' Total Feet of Storage 22' Specification Code: LT5 3S/2S/2R, 1S/1R 12"</p>



FIXED WOOD

ADVANTAGES OF FIXED WOOD

Differentiate your properties with **VUE**®. Give residents the look and feel of custom shelving with no exposed hardware and gap-free installation. From economical shelf and rod solutions to value-added options and accessories, your residents will love **VUE** for years to come.

Why Specify VUE?

VUE® combines quality wood shelving with gap-free installation hardware to create a **refined fixed wood storage solution**. It's the perfect option for when you want a step up from ventilated wire!

- Patent-pending design for gap-free installation and no exposed screws create a clean, polished look.
- Proprietary Tri-Loc anchor hardware and heavy-duty brackets for superior strength.
- Holds 85 lbs per foot of shelving, more than any other fixed wood shelving system available.
- Can be installed to be ADA compliant.
- 3/4" thick thermal fused melamine wood shelving, with radius edgebanding.

Design Spec Level Examples

BASIC • DESIGN LEVEL 2



Single Hang

VU2 2S/1R 12"

Avg Price per Foot of Wall Length \$29

ESSENTIALS • DESIGN LEVEL 3



Double and Single Hang Towers

VU3 2S/2R 12", SS 14", 1S/1R 12"

Avg Price per Foot of Wall Length \$38

DELUXE • DESIGN LEVEL 4



Double and Single Hang Open Slide, Towers with Baskets

VU4 2S/2R 12", SS/Baskets 14", 1S/1R 12"

Avg Price per Foot of Wall Length \$49



















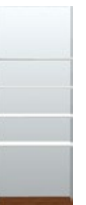





PREMIUM • DESIGN LEVEL 5



Double and Single Hang Open Slide, Towers with Drawers

VU5 2S/2R 12", SS/Drawers 14", 1S/1R 12"

Avg Price per Foot of Wall Length \$60

	BASIC • DESIGN LEVEL 2	ESSENTIALS • DESIGN LEVEL 3	DELUXE • DESIGN LEVEL 4	PREMIUM • DESIGN LEVEL 5
3' ENTRY	 <p>Total Wall Length 3' Total Feet of Storage 3' Specification Code: VU2 1S/1R 12"</p>	 <p>Total Wall Length 3' Total Feet of Storage 6' Specification Code: VU3 2S/1R 12"</p>	 <p>Total Wall Length 3' Total Feet of Storage 6' Specification Code: VU4 2S/1R 12"</p>	 <p>Total Wall Length 3' Total Feet of Storage 9' Specification Code: VU5 2S/1R/Shoe 12"</p>
5' PANTRY	 <p>Total Wall Length 5' Total Feet of Storage 20' Specification Code: VU2 4S 16"</p>	 <p>Total Wall Length 5' Total Feet of Storage 25' Specification Code: VU3 5S 12"</p>	 <p>Total Wall Length 5' Total Feet of Storage 25' Specification Code: VU4 5S 16"</p>	 <p>Total Wall Length 5' Total Feet of Storage 25' Specification Code: VU5 5S, 5S 12"</p>
3' LINEN	 <p>Total Wall Length 3' Total Feet of Storage 12' Specification Code: VU2 4S 16"</p>	 <p>Total Wall Length 3' Total Feet of Storage 15' Specification Code: VU3 5S 12"</p>	 <p>Total Wall Length 3' Total Feet of Storage 15' Specification Code: VU4 1S 12"/4S 16"</p>	 <p>Total Wall Length 3' Total Feet of Storage 15' Specification Code: VU5 5S 16"</p>
6' LAUNDRY	 <p>Total Wall Length 6' Total Feet of Storage 6' Specification Code: VU2 1S 16"</p>	 <p>Total Wall Length 6' Total Feet of Storage 6' Specification Code: VU3 1S/1R 12"</p>	 <p>Total Wall Length 6' Total Feet of Storage 12' Specification Code: VU4 2S/1R 12"</p>	 <p>Total Wall Length 6' Total Feet of Storage 12' Specification Code: VU5 2S/1R 16"</p>
6' REACH-IN BEDROOM	 <p>Total Wall Length 6' Total Feet of Storage 12' Specification Code: VU2 2S/1R 12"</p>	 <p>Total Wall Length 6' Total Feet of Storage 16' Specification Code: VU3 2S/2R 12", SS 14", 1S/1R 12"</p>	 <p>Total Wall Length 6' Total Feet of Storage 20' Specification Code: VU4 2S/2R 12", SS/Baskets 14", 1S/1R 12"</p>	 <p>Total Wall Length 6' Total Feet of Storage 22' Specification Code: VU5 2S/2R 12", SS/Drawers 14", 1S/1R 12"</p>
6'x6' WALK-IN BEDROOM	 <p>Total Wall Length 12' Total Feet of Storage 23' Specification Code: VU2 2S/1R 12"</p>	 <p>Total Wall Length 12' Total Feet of Storage 28' Specification Code: VU3 2S/2R 12", SS 14", 2S/1R 12"</p>	 <p>Total Wall Length 12' Total Feet of Storage 32' Specification Code: VU4 2S/2R 12", SS/Baskets 14", 2S/1R 12"</p>	 <p>Total Wall Length 12' Total Feet of Storage 34' Specification Code: VU5 2S/2R 12", SS/Drawers 14", 2S/1R 12"</p>



ADJUSTABLE

ADVANTAGES OF TRULY ADJUSTABLE SHELVING

freedomRail® is the right storage solution for your project, meeting the needs of current and future residents. Because of our patented hardware, no blocking is required and only the Rail is attached to the wall, making it easy to adjust components and accessories with ease. **freedomRail** meets ADA requirements, making it accessible for all ages and abilities.

Why Specify freedomRail?

freedomRail® is the only **truly adjustable storage** system available on the market. It offers flexibility and ease to change components to meet residents' needs. Accessibility makes it perfect for projects ranging from student housing to senior living!

- 50% more steel than most competitive adjustable storage systems.
- The patented rail guarantees installation into studs and holds 170 lbs per linear foot. No blocking required.
- Fully ADA compliant.
- Furniture-grade laminate, with radius edgebanding.

"70% of renters have walk-in closets on their list of 'must haves'."

— **Cozy**
Apartments.com

"Our residents love the functionality of the (freedomRail) closets. They are able to customize their closets in order to fit their needs"

— **Tiffany Roland**
Gables Residential

Design Spec Level Examples

BASIC • DESIGN LEVEL 2



Single Hang

fR Adj 2S/2R, 2S/1R 14"

Avg Price per Foot of Wall Length \$55

ESSENTIALS • DESIGN LEVEL 3



Double and Single Hang

fR3 Adj 2S/2R, SS, 2S/1R 14"

Avg Price per Foot of Wall Length \$74

DELUXE • DESIGN LEVEL 4



Double and Single Hang Open Slide

fR4 Adj 2S/2R, SS/accs, 2S/1R 14"

Avg Price per Foot of Wall Length \$95

PREMIUM • DESIGN LEVEL 5



Double and Single Hang Open Slide, Shelf Stack

























fR5 Adj 2S/2R, SS/accs, 2S/1R 14"

Avg Price per Foot of Wall Length \$108

freedomRail® DESIGN SPEC LEVEL FOR THE MULTIFAMILY MARKET

BY AREA | BY DESIGN LEVEL



	BASIC • DESIGN LEVEL 2	ESSENTIALS • DESIGN LEVEL 3	DELUXE • DESIGN LEVEL 4	PREMIUM • DESIGN LEVEL 5
3' ENTRY	 <p>Total Wall Length 3' Total Feet of Storage 6' Specification Code: fR2 Adj 2S/1R 14"</p>	 <p>Total Wall Length 3' Total Feet of Storage 6' Specification Code: fR3 Adj 2S/1R 14"</p>	 <p>Total Wall Length 3' Total Feet of Storage 8' Specification Code: fR4 Adj 2S/1R/Canvas Basket 14"</p>	 <p>Total Wall Length 3' Total Feet of Storage 12' Specification Code: fR5 Adj 2S/1R/Shoe 14" Canvas</p>
5' PANTRY	 <p>Total Wall Length 5' Total Feet of Storage 25' Specification Code: fR2 Adj 5S 14"</p>	 <p>Total Wall Length 5' Total Feet of Storage 34' Specification Code: fR3 Adj SS/Tiered Shelf 14"</p>	 <p>Total Wall Length 5' Total Feet of Storage 34' Specification Code: fR4 Adj SS/Tiered Shelf/Baskets 14"</p>	 <p>Total Wall Length 5' Total Feet of Storage 32' Specification Code: fR5 Adj SS/Shoe/Tiered Shelf/Baskets 14"</p>
3' LINEN	 <p>Total Wall Length 3' Total Feet of Storage 15' Specification Code: fR2 Adj 5S 14"</p>	 <p>Total Wall Length 3' Total Feet of Storage 18' Specification Code: fR3 Adj SS 14"</p>	 <p>Total Wall Length 3' Total Feet of Storage 17' Specification Code: fR4 Adj SS/Basket 14"</p>	 <p>Total Wall Length 3' Total Feet of Storage 19' Specification Code: fR5 Adj SS/Baskets 14"</p>
6' LAUNDRY	 <p>Total Wall Length 6' Total Feet of Storage 6' Specification Code: fR2 Adj 1S/1R 14"</p>	 <p>Total Wall Length 6' Total Feet of Storage 12' Specification Code: fR3 Adj 2S/1R 14"</p>	 <p>Total Wall Length 6' Total Feet of Storage 12' Specification Code: fR4 Adj Accs, 2S/1R 14"</p>	 <p>Total Wall Length 6' Total Feet of Storage 12' Specification Code: fR5 Adj accs, 2S/1R 14"</p>
6' REACH-IN BEDROOM	 <p>Total Wall Length 6' Total Feet of Storage 12 Specification Code: fR Adj 2S/2R, 2S/1R 14"</p>	 <p>Total Wall Length 6' Total Feet of Storage 18' Specification Code: fR3 Adj 2S/2R, SS, 2S/1R 14"</p>	 <p>Total Wall Length 6' Total Feet of Storage 20' Specification Code: fR4 Adj 2S/2R, SS/accs, 2S/1R 14"</p>	 <p>Total Wall Length 6' Total Feet of Storage 22 Specification Code: fR5 Adj 2S/2R, SS/accs, 2S/1R 14"</p>
6'x6' WALK-IN BEDROOM	 <p>Total Wall Length 12' Total Feet of Storage 14' Specification Code: fR Adj 2S/2R, 1S/1R 14"</p>	 <p>Total Wall Length 12' Total Feet of Storage 26' Specification Code: fR3 Adj 2S/2R, SS, 2S/1R 14"</p>	 <p>Total Wall Length 12' Total Feet of Storage 28' Specification Code: fR4 Adj 2S/2R, SS/accs, 2S/1R 14"</p>	 <p>Total Wall Length 12' Total Feet of Storage 30' Specification Code: fR5 Adj 2S/2R, SS/accs, 2S/1R 14"</p>



BUILT-IN

ADVANTAGES OF SELECT CLOSETS

Select® is a high-quality affordable solution for multifamily professionals who want a traditional, built-in closet system that residents demand. Select can differentiate your property, increase rental income, and retain residents longer.

Why Specify SELECT?

Select® is the perfect option for residents who want a **traditional, built-in look** and feel for their storage needs. Full extension, soft-close drawer glides, and soft-close hinges create a luxury feel.

- Quality accessories to maximize form and function.
- The patented rail guarantees installation into studs and holds 170 lbs per linear foot. No blocking required.
- Can be installed to be ADA compliant.
- 3/4" thick furniture-grade laminate, with radius edgebanding.

"Residents who are satisfied at move-in are 63% likely to renew."

— **Kingsley Index™**
Kingsley Associates 2016

"Organized Living Select shelving line provides a built-in look at an affordable price point. This durable, attractive, highly customizable shelving line provides an excellent return on investment."

— **Paul Milde, President**
CIP Finishes

Design Spec Level Examples

BASIC • DESIGN LEVEL 2



Double and Single Hang

SE2 Mov 2S/2R, 2S/1R 14"

Avg Price per Foot of Wall Length \$49

ESSENTIALS • DESIGN LEVEL 3

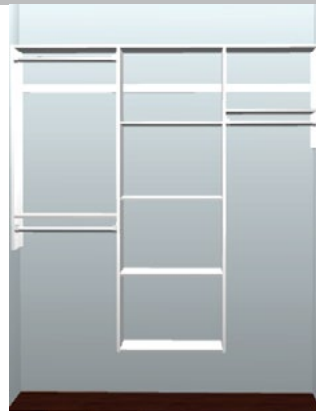

**Double and Single Hang
Shelf Stack**

SE3 Mov 2S/2R, SS, 2S/1R 14"

Avg Price per Foot of Wall Length \$64

DELUXE • DESIGN LEVEL 4



**Shelf Stack
Wire Baskets**

SE4 Mov 2S/2R, SS/Baskets, 2S/1R 14"

Avg Price per Foot of Wall Length \$87

PREMIUM • DESIGN LEVEL 5



**Double and Single Hang
Shelf Stack**





















SE5 Mov 2S/2R, SS/Drawers, 2S/1R 14"

Avg Price per Foot of Wall Length \$121

Select[®] DESIGN SPEC LEVEL FOR THE MULTIFAMILY MARKET

BY AREA | BY DESIGN LEVEL



	BASIC • DESIGN LEVEL 2	ESSENTIALS • DESIGN LEVEL 3	DELUXE • DESIGN LEVEL 4	PREMIUM • DESIGN LEVEL 5
3' ENTRY	 <p>Total Wall Length 3' Total Feet of Storage 6' Specification Code: SE2 Mov 2S/1R 14"</p>	 <p>Total Wall Length 3' Total Feet of Storage 6' Specification Code: SE3 Mov 2S/2R 14"</p>	 <p>Total Wall Length 3' Total Feet of Storage 10' Specification Code: SE4 Mov 2S/2R/Shoe 14"</p>	 <p>Total Wall Length 3' Total Feet of Storage 8' Specification Code: SE5 Mov 2S/2R/Drawer 14"</p>
5' PANTRY	 <p>Total Wall Length 5' Total Feet of Storage 25' Specification Code: SE2 Mov 5S 14"</p>	 <p>Total Wall Length 5' Total Feet of Storage 25' Specification Code: SE3 Mov 5S/Baskets 14"</p>	 <p>Total Wall Length 5' Total Feet of Storage 25' Specification Code: SE4 Mov 5S/Baskets 14"</p>	 <p>Total Wall Length 5' Total Feet of Storage 29' Specification Code: SE5 Mov 5S/Drawers 14"</p>
3' LINEN	 <p>Total Wall Length 3' Total Feet of Storage 15' Specification Code: SE2 Mov 5S 14"</p>	 <p>Total Wall Length 3' Total Feet of Storage 18' Specification Code: SE3 Mov 6S 14"</p>	 <p>Total Wall Length 3' Total Feet of Storage 15' Specification Code: SE4 Mov 5S/Baskets 14"</p>	 <p>Total Wall Length 3' Total Feet of Storage 19' Specification Code: SE5 Mov 5S/Drawers 14"</p>
6' LAUNDRY	 <p>Total Wall Length 6' Total Feet of Storage 9' Specification Code: SE2 Mov 2S/1R 14"</p>	 <p>Total Wall Length 6' Total Feet of Storage 12' Specification Code: SE3 Mov 2S/1R 14"</p>	 <p>Total Wall Length 6' Total Feet of Storage 14' Specification Code: SE4 Mov 1S/1R/Doors 14"</p>	 <p>Total Wall Length 6' Total Feet of Storage 16' Specification Code: SE5 Mov 2S/1R/Doors 14"</p>
6' REACH-IN BEDROOM	 <p>Total Wall Length 6' Total Feet of Storage 12' Specification Code: SE2 Mov 2S/2R, 2S/1R 14"</p>	 <p>Total Wall Length 6' Total Feet of Storage 18' Specification Code: SE3 Mov 2S/2R, SS, 2S/1R 14"</p>	 <p>Total Wall Length 6' Total Feet of Storage 20' Specification Code: SE4 Mov 2S/2R, SS/Baskets, 2S/1R 14"</p>	 <p>Total Wall Length 6' Total Feet of Storage 24' Specification Code: SE5 Mov 2S/2R, SS/Drawers, 2S/1R 14"</p>
6'x6' WALK-IN BEDROOM	 <p>Total Wall Length 12' Total Feet of Storage 20' Specification Code: SE2 Mov 2S/2R, 2S/1R 14"</p>	 <p>Total Wall Length 12' Total Feet of Storage 26' Specification Code: SE3 Mov 2S/2R, SS, 2S/1R 14"</p>	 <p>Total Wall Length 12' Total Feet of Storage 28' Specification Code: SE4 Mov 2S/2R, SS/Baskets, 2S/1R 14"</p>	 <p>Total Wall Length 12' Total Feet of Storage 30' Specification Code: SE5 Mov 2S/2R, SS/Drawers, 2S/1R 14"</p>

ADA

Non-ADA

FIXED

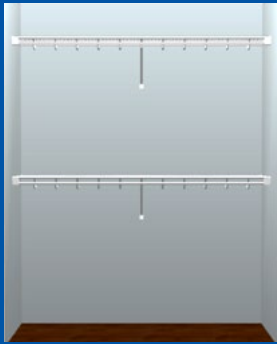

ADA LT2 1S/1R 12"



LT2 1S/1R 12"

ADJUSTABLE

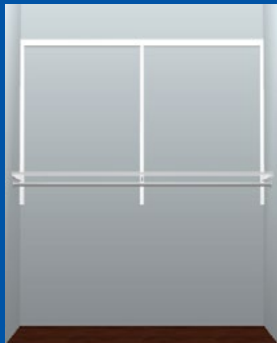

ADA fR1 ADJ 1S/1R 14"



fR1 ADJ 1S/1R 14"

BUILT-IN



ADA SE1 Mov 1S/1R 14"



SE1 Mov 1S/1R 14"

ADA STORAGE

STORAGE DEMANDS

For Architects, Builders, and Property Managers, understanding and complying with the Americans with Disabilities Act (ADA) is critical in order to create a dwelling that is equitable. The Act requires that new Multifamily housing with four or more units be designed and built to allow access for persons with disabilities.

All Organized Living closets can be designed and installed to meet the ADA specifications. Simply add "ADA" to the beginning of the specification code you add to your architect drawings. To meet ADA specifications, the design configuration may have to change slightly. Organized Living takes care of everything by staying up-to-date on ADA requirements and changes and ensuring the designs specified, quoted, and installed meet ADA standards.

Example: **ADA fR3 Adj 2S/1R 14"**



Learn more about ADA requirements.



SUSTAINABLE STORAGE



RESPONSIBLE INSTALLATION

- Minimal hardware required
- On-site delivery options



PRODUCT LIFE-SPAN

- Organized Living products are made to be durable and versatile to last a lifetime, and our products are backed with some of the best warranties in the industry
- No harmful VOCs released in the home
- Long-lasting products minimize waste and reduce landfills
- Epoxy coating won't get sticky over time, extending the usability of the shelf
- No maintenance required



RESPONSIBLE MANUFACTURING

- Epoxy powder coating releases no harmful VOCs during the manufacturing process
- Epoxy powder coating creates minimal waste—it's nearly 100% recycled
- Made in the USA

START SPECIFYING ORGANIZED LIVING TODAY!

Multifamily professionals choose Organized Living for quality products, innovative programs, and unmatched support. We hope this guide has helped you feel confident in specifying our products in your next project.

Should you have any questions about the specification process or partnership, contact our sales team at multifamily@OrganizedLiving.com

“The entire process was easy and seamless – from design all the way through install, everything was executed with precision and professionalism.”

Atit Javeri
Principal, Javeri Capital LLC

Organized
 **Living**